



Grid Solutions
a GE and Alstom joint venture

PROTECTION PRODUCT SOLUTIONS

MiCOM P341 Agile

Interconnection protection and dynamic line rating relay

The MiCOM P341 Agile protection relay offers the interconnection protection necessary for operating machines in parallel with the main power supply network

CUSTOMER BENEFITS

- Maximise usable capacity of overhead line assets by 50% or more
- Increase energy yields, thus improving the cost effectiveness of renewable energy projects and reducing greenhouse gas emissions
- Avoid upgrading or replacing existing transmission lines
- Extensive functionalities to meet all generator protection applications
- Programmable scheme logic to allow easy customization
- Flexible communications options including IEC 61850
- High break output contacts - no reliance on auxiliary devices
- Reduced cost of ownership via redundant ethernet ports
- Redundant communications with zero downtime

Cost-effective and highly reliable protection to optimize transmission line capacity from renewable sources

The P341 provides dynamic line rating (DLR) protection to optimize transmission line capacity, enabling a larger penetration of distributed generation (DG) such as windfarms.

The variable number of opto input and output contacts available allow complex protection schemes to be created using the relay's powerful but easy to use logic.

A choice of industry standard protocols are available on the relay, facilitating an easier integration into both new and existing network control systems.

The optional redundant Ethernet board reduces the cost of ownership since the relay is natively embedded with the switch board. This reduces the amount of standalone switches needed, reducing the wiring, power supply and maintenance costs. Furthermore, increasing the availability rate decreases the risk of power outages.

The P341 provides a flexible and reliable integration of protection, control, monitoring and measurements. Extensive functionality is available to satisfy complete protection and control for a wide range of system applications, including protection for both the connection and generator in simple applications or more sophisticated interconnection protection for larger units, or those connected at higher voltages or DLR applications.

MiCOM Agile P40 series extends the IEC 61850-8-1 station bus to include Parallel Redundancy Protocol (PRP), which offers a vendor-interoperable solution to implement redundant communications. It has the advantage of taking zero time to recover from a failure, as parallel alternative paths are continually operative. This compares to 25 ms or more healing time for legacy techniques such as RSTP.

MiCOM P40 Agile

Grid Solutions' philosophy is one of continuous improvement in our products and solutions. Our emphasis on communication in MiCOM has become a focus which secures leadership in the digital substation. To mark this phase of evolution, the P40 Agile livery is applied to the range. P40 Agile is a mark of performance and quality, proudly available from Grid Solutions, and only from Grid Solutions.



MiCOM P341 Agile
Interconnection protection and DLR relay

APPLICATION

With embedded generators running in parallel with the normal public supply there is a risk that, due to fault clearances on the external system, the embedded generator may become disconnected (islanded) from the main supply network. The machines may continue to supply external load, but there is a significant risk the islanding may cause: loss of system earth where the system earth is on the star winding of a network transformer or poor quality of supply to local loads and unsynchronized reconnection due to auto-reclosure of the remote circuit-breaker. Rate of change of frequency and voltage vector shift protection functions are provided to detect this loss of mains/grid (or islanded) conditions.

The P341 also provides overcurrent and ground fault, under and over-voltage, under and overfrequency, thermal overload, negative phase sequence overcurrent and over-voltage and power/VAr protection for the point of connection of the embedded generator and supply network.

Check synchronizing is also included to supervise the closing of the circuit-breaker.

The P341 also provides Dynamic Line Rating protection to optimize transmission line capacity, enabling a larger penetration of distributed generation such as windfarms.

GLOBAL FUNCTIONS

The following global functions are generally available:

- 4 settings groups
- Metering
- Event recording
- Disturbance recording
- Fault recording
- Breaker state and condition monitoring
- 6 languages: English, French, German, Spanish, Russian, Chinese

FUNCTIONAL OVERVIEW

ANSI	IEC 61850	FEATURES	ANSI
81R	DfpPFRC	Rate of change of frequency	4
DVq	VvsPVSP	Voltage vector shift	1
50/51/67	OcpPTOC	Directional / non directional, instantaneous / time delayed phase overcurrent	4
50N/51N/67N	EfmPTOC	Directional / non directional, instantaneous / time delayed phase ground fault	4
67N/67W	SenSefPTOC	Sensitive directional ground fault / wattmetric ground fault	4
64	SenRefPDIF	Restricted earth fault	1
59N	VtpResPTOV	Neutral voltage displacement/residual overvoltage interturn - measured (M), derived (D)	2M/2D
27/59	VtpPhsPTUV/PTOV	Under/Over voltage	3/2
81U/81O	FrqPTUF/PTOF	Under/Over frequency	4/2
32P/Q	PwrPPWR	Forward/Reverse, Under/Over Power/VAr	4
49	ThmPTTR	Stator thermal overload	2
49DLR	DrpOhlPTTR	Dynamic Line Rating (DLR)	Option
46	NpsPTOC	Directional/non directional, negative phase sequence overcurrent	4
47	NpsPTOV	Negative phase sequence overvoltage	1
50BF	CbfRCFB	CB fail	2
	SvnRVCS	Current transformer supervision	1
	SvnRVCS	Voltage transformer supervision	1
25	AscRSYN	Check synchronizing	2
		Number of settings groups	4
	ClIAIm/TrpPTUC	CLIO (4 analogue inputs + 4 analogue outputs)	Option
		IRIG-B time synchronization (modulated/demodulated)	Option
		Front communications port (EIA (RS) 232 9-pin)	•
		Rear communications port (EIA (RS) 485 / K-Bus) (COMM1/RP1)	•
		Rear communications fibre optic/ethernet/redundant ethernet port (COMM1/RP1)	Option
		2nd rear communications port (COMM2)	Option
	OptGGIO	Opto inputs	8-24
	RlyGGIO	Output contacts	7-24
	LedGGIO	Programmable LEDs	8

FUNCTIONAL OVERVIEW

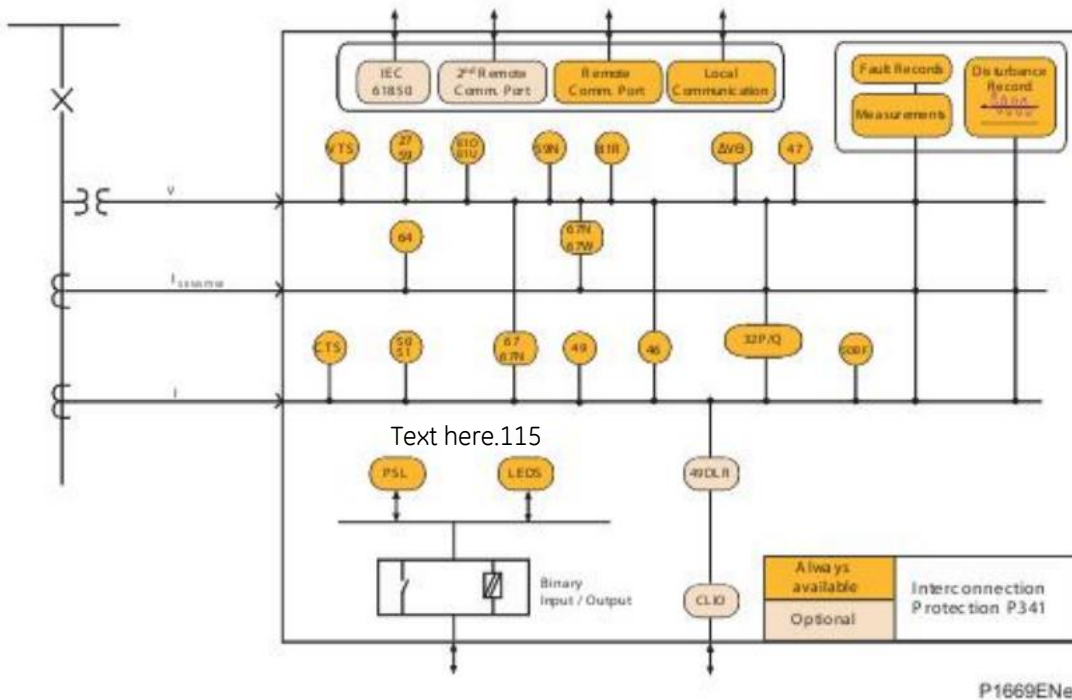

MAIN PROTECTION FUNCTIONS

The main protection functions are autonomous and can be individually enabled or disabled to suit a particular application. Each protection function is available in four separate settings groups which can be individually enabled or disabled. 3-phase tripping with faulted phase indication is provided for all protection functions.

LOSS OF MAINS

With embedded generators running in parallel with the normal public supply there is a risk that, due to fault clearances on the external system, the embedded generator may become disconnected (islanded) from the main supply network.

The machines may continue to supply external load and there is a significant risk the islanding may cause: loss of system earth where the system earth is on the star winding of a network transformer, poor quality of supply to local loads and unsynchronized reconnection due to auto-reclosure of the remote circuit breaker.

A loss of the mains/grid (or islanded) condition can be detected using voltage, frequency and power protection, but when the machine rating closely matches the connected load this condition may be difficult to detect. Two methods of detection are therefore offered: rate of change of frequency and voltage vector shift.

RATE OF CHANGE OF FREQUENCY

The four df/dt stages can be used to detect the fluctuation in frequency that will occur as the machine adjusts to the new load conditions following loss of the grid or they can be used for load shedding applications.

The number of frequency averaging cycles, number of protection iterations, operating mode – fixed or rolling window and direction of operation can be set to suit the application. To improve stability for external system events, an adjustable definite time delay can be used.

MiCOM P341 Agile: Comprehensive protection for all your interconnection requirements

VOLTAGE VECTOR SHIFT

This protection measures the instantaneous change in the 3-phase voltage angle that occurs when the connection to the main supply network is lost. To provide stability, this element must be less sensitive than the rate of change of frequency element. However, it operates without any intentional time delay, providing fast tripping.

PHASE OVERCURRENT

Four independent overcurrent stages are available. Each stage may be selected as non-directional or directional (forward/reverse). All stages have definite time (DT) delayed characteristics, two of the stages may also be independently set to one of nine inverse definite minimum time (IDMT) curves (IEC and IEEE) or to one of 4 user programmable curves. The IDMT stages have a programmable reset timer for grading with electromechanical relays to reduce autoreclose dead times and to reduce clearance times where intermittent faults occur. The phase fault directional elements are internally polarised by quadrature phase-phase voltages, and will make a correct directional decision down to 0.5 V ($V_n = 110/120$ V) or 2.0 V ($V_n = 380/440$ V).

A synchronous polarising signal is maintained for 3.2s after voltage collapse to ensure that the instantaneous and time delayed overcurrent elements operate correctly for close-up 3-phase faults.

STANDARD GROUND FAULT

The standard ground fault element operates from a residual current that is derived internally from the summation of the 3-phase currents. The directionality of the ground fault elements is provided by either residual voltage or negative sequence voltage. Voltage transformer supervision (VTS) can be used to block the directional element or to revert it to non-directional.

Four independent stages are available. Each stage may be selected as non-directional or directional (forward/reverse). All stages have definite time (DT) delayed characteristics, two of the stages may also be independently set to one of ten inverse definite minimum time (IDMT) curves (IEC and IEEE) or to one of 4 user programmable curves.

SENSITIVE GROUND FAULT

A core balance CT should be used to drive the sensitive ground fault function. The directionality of the sensitive ground fault elements is provided by the residual voltage.

Four independent stages are available. Each stage may be selected as non-directional or directional (forward/reverse). All stages have definite time (DT) delayed characteristics, two of the stages may also be independently set to one of ten inverse definite minimum time (IDMT) curves (IEC and IEEE) or to one of 4 user programmable curves.

WATTMETRIC

The sensitive ground fault protection is also suitable for Petersen Coil grounded systems by enabling a wattmetric element. This form of protection uses the sensitive ground fault protection directional characteristic, but with a directional residual power threshold providing an additional constraint on operation.

RESTRICTED GROUND FAULT

The sensitive ground fault element may be configured as a high impedance differential restricted ground fault element. When high impedance restricted ground fault protection is used, an additional stabilising resistance and a metrosil will be required.

BLOCKED OVERCURRENT LOGIC

Each stage of overcurrent, ground fault and sensitive ground fault protection can be blocked by an optically isolated input. This enables the overcurrent and ground fault protection to be integrated into a blocked overcurrent busbar protection scheme.

NEUTRAL DISPLACEMENT / RESIDUAL OVERVOLTAGE

Two stages of measured and calculated residual overvoltage (or neutral voltage displacement) protection are provided in the P341.

Depending on the VT configuration, the protection will operate from either an internally calculated value from the 3-phase to neutral voltage measurements, a directly measured value of residual voltage from a broken delta VT, or from the secondary winding of a distribution transformer ground at the generator neutral.

Each stage can be set with a definite time delay or an inverse time delay or a user programmable curve characteristic. This function provides protection against ground faults irrespective of the system grounding connection used.

UNDER / OVERVOLTAGE

Under/overvoltage protection may be configured to operate from either phase-phase or phase-neutral voltage elements.

Three independent undervoltage stages and two overvoltage stages with definite time elements are available for under and overvoltage protection. The first stage can also be configured to an inverse time or a user programmable curve characteristic.

MiCOM P341 Agile : dual loss of mains protection - df/dt and voltage vector shift

UNDER / OVERFREQUENCY

The P341 provides two independent stages of overfrequency and four of under frequency. Each stage functions as a definite time element.

POWER PROTECTION

Four definite time stages of power/VAr protection are provided and each stage can be independently configured to operate as under/over and forward/ reverse. The reverse power/VAr protection can be used for loss of mains protection where the generating plant capacity is such that the site will always import power from the distribution system, tripping when import of power reverses. The P341 relay provides a standard 3 phase power/VAr protection element and also a single phase sensitive power/VAr protection element. The sensitive power/VAr protection can be used with a dedicated metering class CT using the sensitive current input.

THERMAL OVERLOAD

To monitor the thermal state of a generator or a feeder, a thermal replica protection is provided. The thermal element has a trip and an alarm stage. Positive and negative sequence currents are taken into account so that any unbalanced condition can be detected and any abnormal heating of the rotor can be avoided. There are separate time constants for heating and cooling and in the event of loss of auxiliary supply, the thermal state is stored in non volatile memory.

NEGATIVE PHASE SEQUENCE OVERCURRENT

Four definite time negative phase sequence overcurrent stages are available within the P341. Each stage may be selected as non-directional or directional (forward/reverse) and can operate for remote phase-phase and phase-ground faults even with delta-star transformers present.

NEGATIVE PHASE SEQUENCE OVERVOLTAGE

One definite time stage of negative phase sequence overvoltage protection is provided within the P341. Negative phase sequence overvoltage protection can be used for the detection of voltage unbalance which can quickly lead to overheating and damage of generators.

ANALOG (CURRENT LOOP) INPUTS AND OUTPUTS (CLIO)

Four analog (or current loop) inputs are provided for transducers with ranges of 0-1 mA, 0-10 mA, 0-20 mA or 4-20 mA. The analog inputs can be used for various transducers such as vibration monitors, tachometers and pressure transducers. Associated with each input there are two time delayed protection stages, one for alarm and one for trip. Each stage can be set for 'Over' or 'Under' operation. Four analog (or current loop) outputs are provided with ranges of 0-1 mA, 0-10 mA, 0-20 mA or 4-20 mA which can alleviate the need for separate transducers. These may be used to feed standard moving coil ammeters for analog indication of certain measured quantities or plugged into a SCADA using an existing analog RTU.

DYNAMIC LINE RATING (DLR) (P341 V7x software)

The P341 provides Dynamic Line Rating (DLR) protection to optimise trans-mission line capacity. Gains of up to 50% or more can be achieved, depending on the environmental conditions, enabling more Distributed Generation (DG) such as windfarms to be connected to the grid by taking into account the real time weather conditions to calculate the line rating rather than using fixed summer/winter line ratings.

DLR is a cost effective alternative to reinforcing overhead lines to increase capacity and there are also benefits to the windfarm owner in that higher revenues can be made with a higher line rating.

DLR calculates the real time rating (ampacity) of the line from some or all of the local weather measurements - wind speed, wind direction, ambient temperature and solar radiation via the transducer (current loop) inputs and compares this rating to the line current. The relay has six definite time DLR stages which can be set as a percentage of the line ampacity. These stages can be used for load management by sending commands to the DG to hold or reduce their output when the line current is close to the line rating and also as a back-up - in case the windfarm power output is not reduced, the relay can initiate tripping of the DG.

PHASE ROTATION

A facility is provided to maintain correct operation of all the protection functions even when the generator is running in a reverse phase sequence. This is achieved through user configurable settings available in four settings groups. The phase rotation for all 3-phase currents and voltages can be reversed. Also, for pump storage applications where two phases are swapped for pumping operation, the swapping of the phases can be emulated in the relay via settings for the 3-phase currents and voltages.

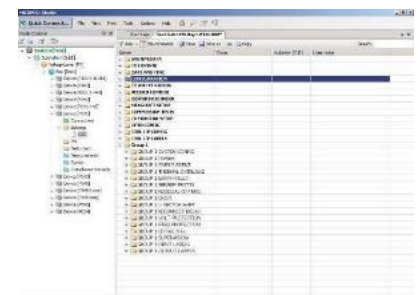

Figure 1 Simple function selection by mouseclick

SUPERVISORY FUNCTIONS

Circuit-breaker failure protection

Two stage circuit-breaker failure protection may be used for tripping upstream circuit-breakers and/or the local secondary trip coil. The circuit-breaker failure logic may also be initiated externally from other protection devices if required.

Voltage transformer supervision

Voltage transformer supervision (VTS) is provided to detect loss of one, two or three VT signals, providing indication and inhibition of voltage dependent protection elements. An optically isolated input may also be configured to initiate the voltage transformer supervision alarm and blocking when used with miniature circuit-breakers (MCBs) or other external forms of voltage transformer supervision.

Current transformer supervision

Current transformer supervision (CTS) is provided to detect loss of phase CT signals and inhibit the operation of current dependent protection elements.

Trip circuit monitoring

Monitoring of the trip circuit in both breaker open and closed states can be realized using the programmable scheme logic.

Circuit-breaker state monitoring

In the P341, an alarm will be generated if there is a discrepancy between the open and closed contacts of the circuit-breaker.

Circuit-breaker condition monitoring

The circuit-breaker condition monitoring features include:

- monitoring the number of breaker trip operations
- recording the sum of the broken current quantity $I_x, 1.0 \times 2.0$
- monitoring the breaker operating times

CONTROL

Circuit-breaker control and check synchronising

Circuit-breaker control is available from the front panel user interface, optically isolated inputs and remotely via the substation communications.

Check synchronizing is included to verify that the generator frequency, voltage magnitude and phase angle match the system's before allowing the generator breaker to be closed. Transformer vector compensation is also included.

Programmable scheme logic

Programmable scheme logic in the P341 allows the user to customize the protection and control functions. It is also used to program the functionality of the digital inputs, output contacts and LED indications. The programmable scheme logic comprises gate logic and general purpose timers. The gate logic includes OR, AND and majority gate functions, with the ability to invert the inputs and outputs and provide feedback. The system is optimized to evaluate changes to the scheme logic signals and thus minimize any delays in logic execution. The programmable scheme logic may be configured using the graphical S1 Agile PC based support software, as illustrated in figure 2.

The required logic is drawn as shown below and is then downloaded directly into the relay. The logic may also be uploaded from the relay and then modified using S1 Agile support software.

Control inputs

The ON/OFF status of 32 control inputs can be changed manually or remotely via the communications to provide user defined control functions within the P341 PSL.

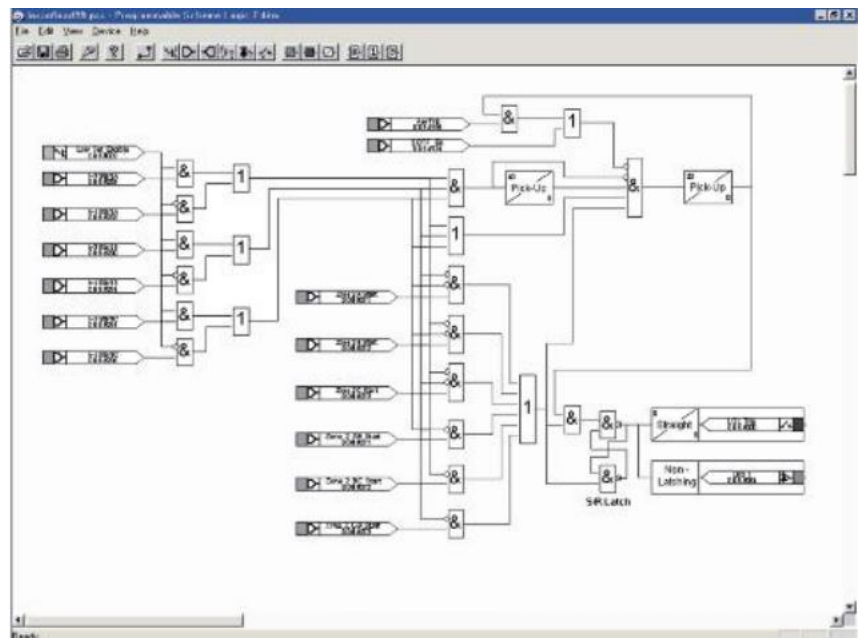

Figure 2 PSL Editor (S1 Studio)

Comprehensive post-fault analysis and communications options

LATCHED OUTPUT CONTACTS

Each P341 relay output contact can be individually programmed to be latched. Once in the latched state, the contact can be reset either locally, remotely or via the PSL.

In addition to the ability to latch output contacts, each of the contacts can be individually conditioned by a timer to give pulse, dwell, delay on pick-up or delay on drop-off operation.

MEASUREMENT AND POST FAULT ANALYSIS

The P341 is capable of measuring and storing a number of quantities. All events, faults and disturbance records are time stamped to a resolution of 1 ms using an internal real time clock. A pulsed opto input or an optional IRIG-B port is also available to maintain the accuracy of the real time clock. A supervised and easily accessed lithium battery ensures that the real time clock and records are maintained during auxiliary supply interruptions.

POWER SYSTEM MEASUREMENTS

The measurements provided will depend upon the application and model of the relay. Where appropriate, the measurements may be viewed in primary or secondary terms and can be viewed locally or remotely.

Measurements include:

- Phase / line voltages
- Sequence voltages
- Phase angles
- System frequency
- Phase / line currents
- Sequence currents
- W/Var/VA

EVENT RECORDING

The P341 relay can store up to 512 event records for viewing locally via the LCD, or extracted via the communications ports.

FAULT RECORDING

The relays store the last five fault records, typically containing:

- Date and time
- Protection operation
- Active settings group
- Fault voltages, frequency, etc.

DISTURBANCE RECORDING

The relays have an internal waveform capture facility with a user programmable trigger point. The P341 can record 10 disturbances, each with a duration of 7.5 seconds (75 s maximum) at a sampling rate of 24 samples per cycle. All disturbance records capture both analog and digital information and when extracted via the communications ports, are stored in Comtrade format. These records can be examined using S1 Agile or any other suitable software program.



INFORMATION INTERFACES

Information exchange is done via the local control panel, the front PC interface, the main rear communications interface (COMM1) or an optional second rear interface (COMM2).

LOCAL COMMUNICATIONS

The front EIA(RS)232 communications port has been designed for use with S1 Agile software and is primarily for configuring the relay settings and programmable scheme logic. It is also used to locally extract event, fault and disturbance record information and can be used as a commissioning tool by viewing all relay measurements simultaneously.

REAR COMMUNICATIONS

The P341 main rear communications interface supports the five protocols listed below (selected at time of order) and is intended for integration with substation control systems.

- Courier/K-Bus
- Modbus
- IEC 60870-5-103*
- DNP 3.0
- IEC61850

IEC 61850 and DNP 3.0 are available when the optional ethernet or redundant ethernet port is ordered. IEC 61850 offers high-speed data exchange, peer-to-peer communications, reporting, disturbance record extraction and time synchronization.

An optional fiber-optic interface is available for any of the above protocols with the P341.

An optional 2nd rear communications port with the Courier protocol is available. This port is intended for central settings or remote access with S1 Agile.

Clock synchronization can be achieved using one of the protocols or using the IRIG-B input or using an opto input.

REDUNDANT ETHERNET PORTS (IEC61850) (P341)

Px4x devices can be enhanced with an optional redundant Ethernet board. The redundancy is managed by the market's fastest recovery time protocols: self healing protocol and dual homing protocol allowing bumpless redundancy. IEC 62439 PRP and RSTP (Rapid Spanning Tree) protocol are also available, offering multi-vendor interoperability with PRP providing bumpless redundancy. The redundant Ethernet board supports either modulated or demodulated IRIG-B and the SNTP protocol for time synchronization. The redundant Ethernet board also has a watchdog relay contact to alarm in case of a failure.

PASSWORD PROTECTION

To prevent unauthorised settings changes, the P341 Agile provides two password levels.

GRID SOLUTIONS' TRACK RECORD - INTERCONNECTION PROTECTION

- KVFG/MX3VI: First numerical relays combining voltage and frequency protection features. Over 3,600 devices installed since 1996.
- P94x: Designed for all frequency based load applications. Over 2,000 units installed since 1999.
- P342-6: Designed for all generator protection applications. Over 6,000 units installed since 1999.
- P341: Designed for all interconnection protection applications. Over 1,000 units installed since 1999.



EMC COMPLIANCE
89/336/EEC

Compliance with the European Commission Directive on EMC



PRODUCT SAFETY
73/23/EEC

Compliance with the European Commission Low voltage directive



P34X THIRD PARTY COMPLIANCE

File Number : E202519
Original issue date : 05-10-2002
(Complies with Canadian and US requirements)



Certificate number : 104 Issue 2
Assessment date : 16-04-2004

QUALITY BUILT-IN (QBI)

Grid Solutions' QBi initiative has deployed a number of improvements to maximize field quality. Harsh environmental coating is applied to all circuit boards to shield them from moisture and atmospheric contamination. Transit packaging has been redesigned to ISTA standard, and the third generation of CPU processing boosts not only performance, but also reliability.

For more information please contact
GE Grid Solutions

Worldwide Contact Center

Web: www.GEGridSolutions.com/contact
Phone: +44 (0) 1785 250 070

www.GEGridSolutions.com

